

5KFC3516



**KitchenAid**

# TABLE OF CONTENTS

<b>PARTS AND FEATURES</b> .....	6
Parts and accessories.....	6
<b>MINI FOOD PROCESSOR SAFETY</b> .....	7
Important safeguards .....	7
Electrical requirements .....	10
Electrical equipment waste disposal .....	10
<b>USING THE MINI FOOD PROCESSOR</b> .....	11
Speed recommendations chart .....	11
Preparing the Mini Food Processor for use.....	12
Disassembling the Mini Food Processor .....	13
Assembling and running the Mini Food Processor .....	14
Using the drizzle basin and pour spout .....	15
<b>CARE AND CLEANING</b> .....	16
<b>TROUBLESHOOTING</b> .....	17
<b>WARRANTY AND SERVICE</b> .....	18



# PARTS AND FEATURES

## PARTS AND ACCESSORIES

---

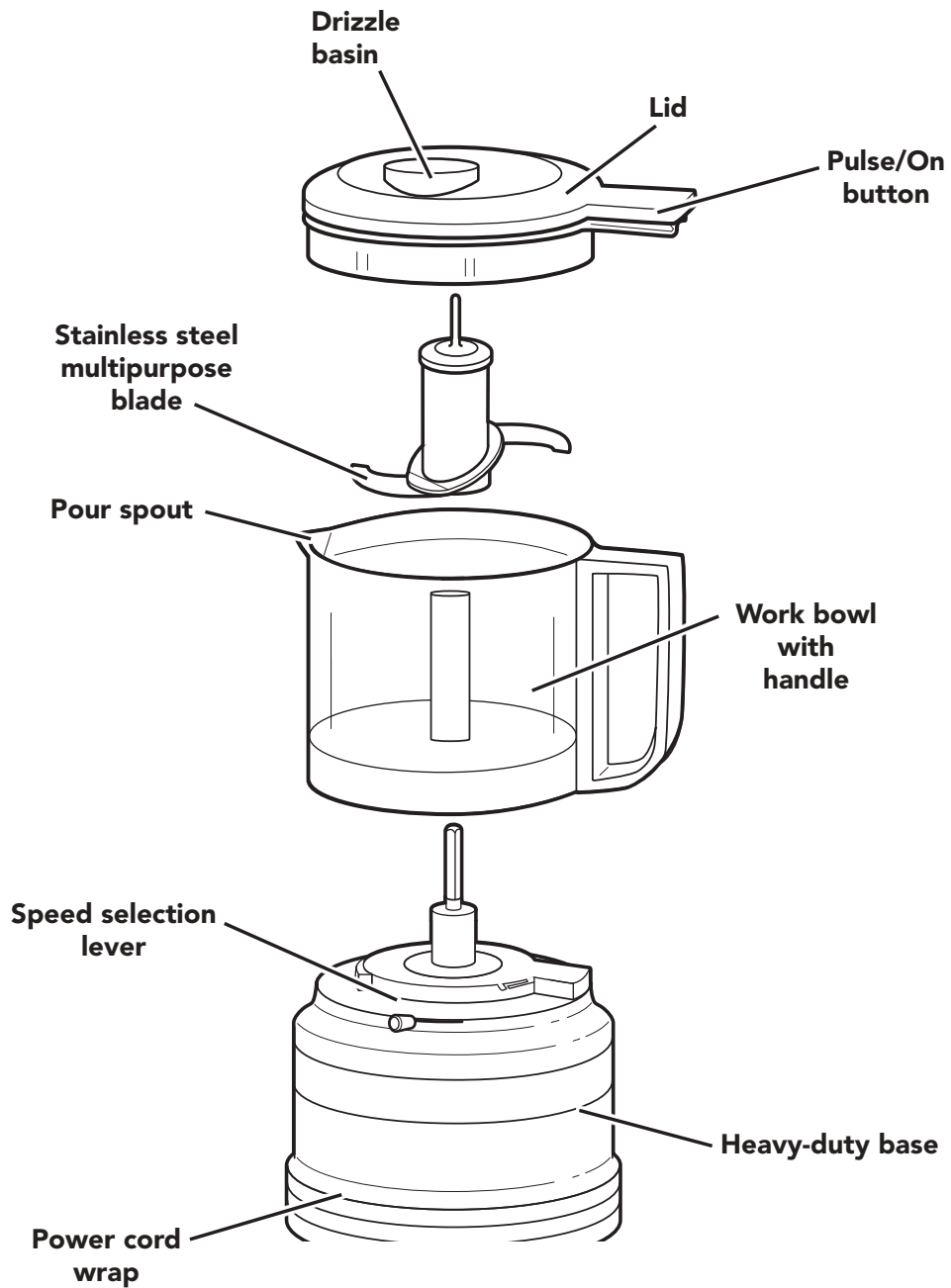

## Your safety and the safety of others are very important.

We have provided many important safety messages in this manual and on your appliance. Always read and obey all safety messages.



This is the safety alert symbol.

This symbol alerts you to potential hazards that can kill or hurt you and others.

All safety messages will follow the safety alert symbol and either the word “DANGER” or “WARNING.” These words mean:

 **DANGER**

**You can be killed or seriously injured if you don't immediately follow instructions.**

 **WARNING**

**You can be killed or seriously injured if you don't follow instructions.**

All safety messages will tell you what the potential hazard is, tell you how to reduce the chance of injury, and tell you what can happen if the instructions are not followed.

## IMPORTANT SAFEGUARDS

**When using electrical appliances, basic safety precautions should always be followed, including the following:**

1. Read all instructions. Misuse of appliance may result in personal injury.
2. To protect against risk of electrical shock, do not put Mini Food Processor in water or other liquid.
3. This appliance is not intended for use by persons with reduced physical, sensory, or mental capabilities, or lack of experience and knowledge, unless they have been given supervision or instructions concerning use of the appliance in a safe way and understand the hazards involved.
4. Children should be supervised to ensure they do not play with the appliance. The appliance is not to be used by children. The appliance and cord should be out of reach of children. Children shall not clean or perform user maintenance on the appliance without supervision.

## MINI FOOD PROCESSOR SAFETY

5. Unplug from the outlet when not in use, before putting on or taking off parts, and before cleaning.
6. Avoid contacting moving parts.
7. Do not operate any appliance with a damaged cord or plug, or after the appliance malfunctions, or is dropped or damaged in any manner. Return appliance to the nearest Authorised Service Facility for examination, repair, or electrical or mechanical adjustment.
8. The use of attachments not recommended or sold by KitchenAid may cause fire, electric shock, or injury.
9. Do not use outdoors.
10. Do not let cord hang over edge of table or counter.
11. Keep hands and utensils away from moving blades while processing food to reduce the risk of severe injury to persons or damage to the Mini Food Processor. A scraper may be used but must be used only when the Mini Food Processor is not running.
12. Blades are sharp. Care should be taken when handling the sharp cutting blades, emptying the bowl, and during cleaning.
13. To reduce the risk of injury, never place cutting blade on base without first putting bowl properly in place.
14. Be certain cover is securely locked in place before operating appliance.
15. Do not attempt to defeat the cover interlock mechanism.

## MINI FOOD PROCESSOR SAFETY

16. This appliance is intended to be used in household and similar applications such as:
  - staff kitchen areas in shops, offices, or other working environments
  - farmhouses
  - by clients in hotels, motels and other residential type environments
  - bed and breakfast type environments.
17. Be careful if hot liquid is poured into the Mini Food Processor as it can be ejected out of the appliance due to a sudden steaming.

## SAVE THESE INSTRUCTIONS

**This product is designed for household use only.**



# MINI FOOD PROCESSOR SAFETY

## ELECTRICAL REQUIREMENTS

---

**Voltage:** 220-240 Volts

**Frequency:** 50-60 Hertz

**Wattage:** 240 Watts

**NOTE:** If the plug does not fit in the outlet, contact a qualified electrician. Do not modify the plug in any way.

## ELECTRICAL EQUIPMENT WASTE DISPOSAL

---

### Disposal of packing material

The packing material is 100% recyclable and is marked with the recycle symbol . The various parts of the packing must therefore be disposed of responsibly and in full compliance with local authority regulations governing waste disposal.

### Scrapping the product

- This appliance is marked in compliance with European Directive 2012/19/EU, Waste Electrical and Electronic Equipment (WEEE).
- By ensuring this product is disposed of correctly, you will help prevent potential negative consequences for the environment and human health, which

could otherwise be caused by inappropriate waste handling of this product.



- The symbol  on the product or on the accompanying documentation indicates that it should not be treated as domestic waste but must be taken to an appropriate collection centre for the recycling of electrical and electronic equipment.

For more detailed information about treatment, recovery and recycling of this product, please contact your local city office, your household waste disposal service or the shop where you purchased the product.



# USING THE MINI FOOD PROCESSOR

## SPEED RECOMMENDATIONS CHART

Use the Mini Food Processor to chop raw fruits and vegetables or nuts, and mince parsley, chives, or garlic for easy preparation in your favorite recipes. Purée cooked fruit or vegetables to make baby food or to use as bases for soups or sauces. You can also make bread crumbs or grind raw meat. Use the drizzle basin and pour spout to easily make mayonnaise or dressings.

**NOTE:** For best results, larger food items should be cut into approximately 1-inch cubes before processing. This step also allows processing of more food at a single time.

**IMPORTANT:** Do not process coffee beans or hard spices such as nutmeg, which may damage the Mini Food Processor.

SUGGESTED FOOD	PREPARE FOR PROCESSING	AMOUNT	SPEED
RAW FRUITS & VEGETABLES	Cut into 1 inch pieces.	Up to 3 cups	1 or 2
COOKED FRUITS & VEGETABLES	Cut into 1 inch pieces.	Up to 2.5 cups	2
LIQUIDS/ EMULSIONS (SUCH AS MAYONNAISE OR SALAD DRESSINGS)	Place dry ingredients or thicker wet ingredients in work bowl; then use the drizzle basin to add oils or liquids to the mixture during use.	Up to 1.5 cups	2



# USING THE MINI FOOD PROCESSOR

SUGGESTED FOOD	PREPARE FOR PROCESSING	AMOUNT	SPEED
MEAT	Meat should be raw and cut into 1 inch pieces for best processing results.	Up to 1/2 pound (227g) at one time.	1 or 2
HERBS & SPICES	Add herbs and spices as they are; no preparation needed.	Up to 3 cups	1
BREAD, COOKIES, OR CRACKERS	Break bread, crackers, or cookies into pieces that fit into the bowl before processing.	Up to 3 cups	1
NUTS	Add nuts as they are; no preparation needed.	Up to 3 cups	2

**TIP:** For better consistency, or to achieve coarsely chopped results, use the Pulse operation.

## PREPARING THE MINI FOOD PROCESSOR FOR USE

### **WARNING**

#### **Cut Hazard**

**Handle blades carefully.**

**Failure to do so can result in cuts.**

#### **Before first use**

Before using the Mini Food Processor for the first time, wash the work bowl, lid, and blade in hot, soapy water. Work bowl, lid, and blade may also be washed in the top rack of a dishwasher.

For convenient storage, always reassemble the Mini Food Processor after cleaning.

# USING THE MINI FOOD PROCESSOR

## DISASSEMBLING THE MINI FOOD PROCESSOR

Follow these instructions to disassemble the Mini Food Processor for cleaning and when removing ingredients from the work bowl.

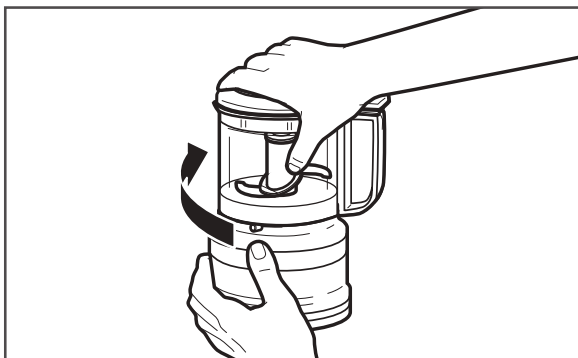

- 1** Be sure the Mini Food Processor is unplugged. Hold the lid as shown and rotate it clockwise to unlock. Then lift the lid off of the work bowl.

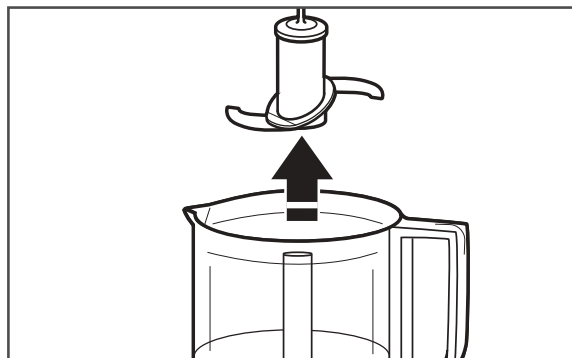

- 2** Pull the blade straight up to unlock and remove it from the work bowl.

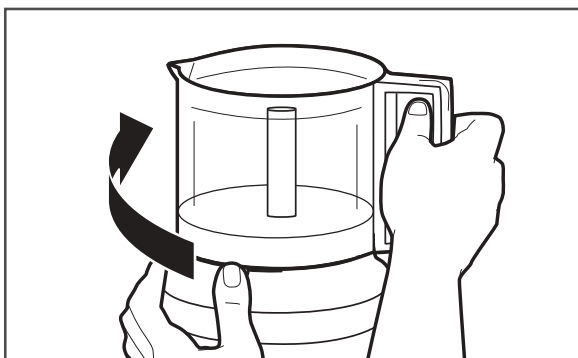

- 3** Hold the base steady with one hand, and use the other hand to rotate the work bowl clockwise to unlock and lift it off of the base.

# USING THE MINI FOOD PROCESSOR

## ASSEMBLING AND RUNNING THE MINI FOOD PROCESSOR

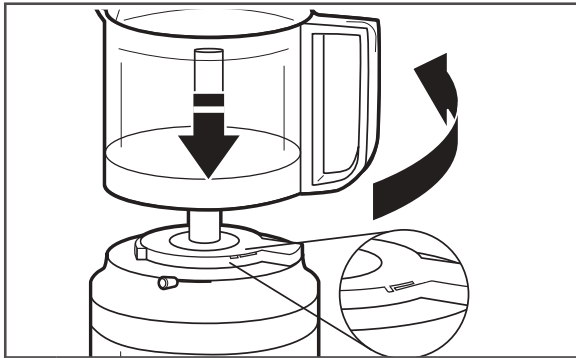

- 1** Be sure the Mini Food Processor is unplugged. Start with the work bowl handle facing front on the base. Rotate the handle 90° counterclockwise to lock into place. When assembled properly, the handle will face the right side.

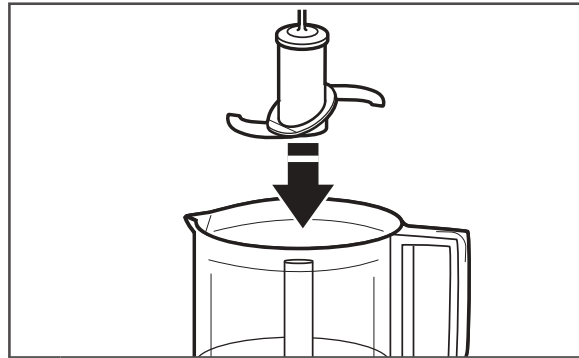

- 2** Fit the blade over the shaft in the centre of the work bowl, rotate and press down until it locks into position.

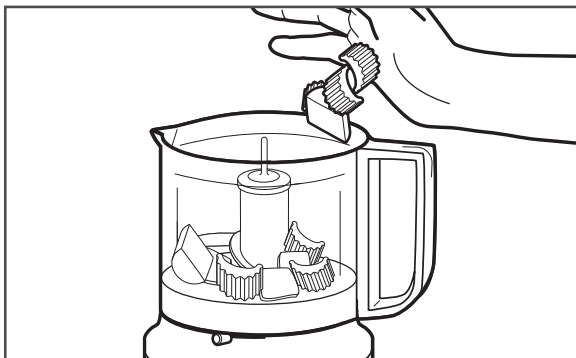

- 3** Place ingredients to be processed inside the work bowl. For uniform consistency of processed foods, cut fruits, vegetables, and meats into 1-inch pieces.

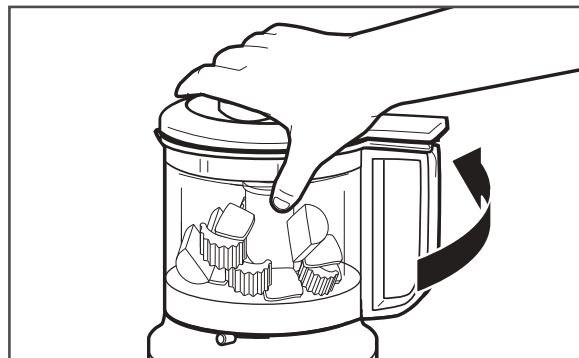

- 4** Place the lid on the work bowl with the lid handle facing front. Rotate the lid handle to the right. The lid will click when locked into place. Rotate the lid counterclockwise to lock into place.

**IMPORTANT:** Do not process coffee beans or hard spices such as nutmeg, which may damage the Mini Food Processor.

**NOTE:** The work bowl and lid must be locked into place for the Mini Food Processor to operate.

# USING THE MINI FOOD PROCESSOR

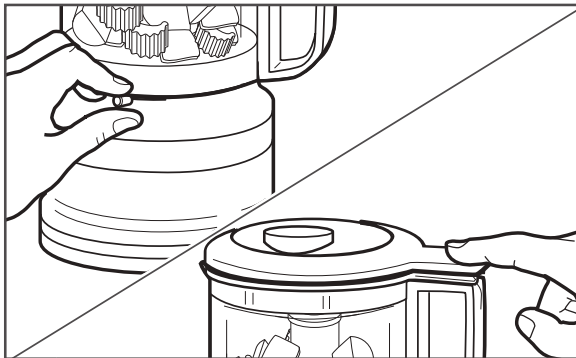

**5** Slide the speed lever to your desired setting. Press down on the PULSE/ON button to start the Mini Food Processor. Do not chop any food for more than 30 seconds continuously; pause between uses.

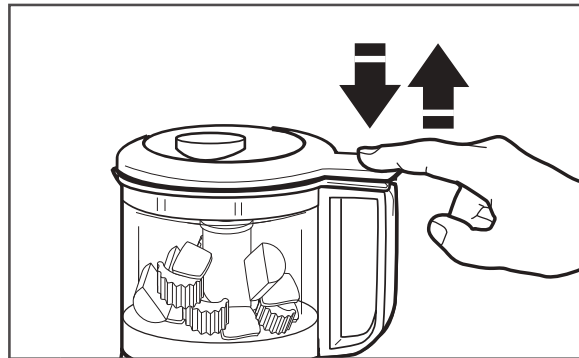

**6** For a coarse chop, use a pulsing motion to rapidly press and release the PULSE/ON button until your desired results are achieved.

## USING THE DRIZZLE BASIN AND POUR SPOUT

Use the drizzle basin to conveniently add liquid ingredients while processing, to make dressings, mayonnaises, emulsions, sauces, and more. Use the pour spout for easier serving.

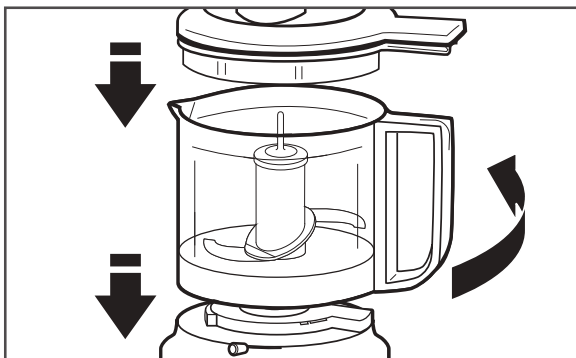

**1** Place the lid on the work bowl with the lid handle facing front. Rotate the lid handle to the right. Rotate the lid counterclockwise to lock into place.

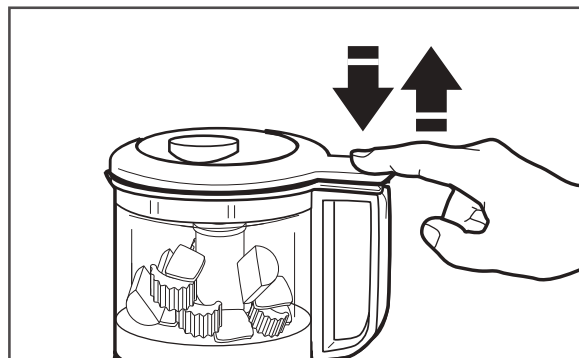

**2** Press rapidly up and down on the PULSE/ON button to get your ingredients moving in the work bowl.

## USING THE MINI FOOD PROCESSOR



- 3** Slowly pour liquids, such as oil, into the drizzle basin. The liquid will be efficiently and thoroughly mixed into the ingredients as they spin inside the work bowl.

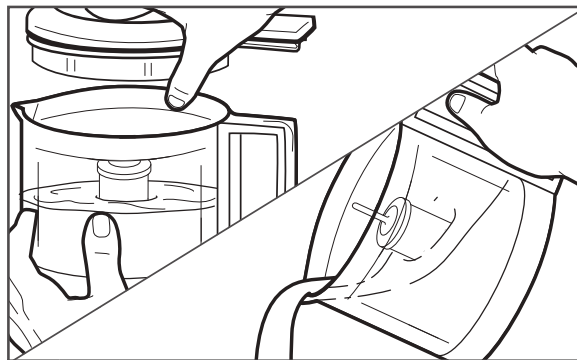

- 4** Once processing is complete, remove the lid to use the pour spout.

## CARE AND CLEANING

### **! WARNING**

#### **Cut Hazard**

**Handle blades carefully.**

**Failure to do so can result in cuts.**

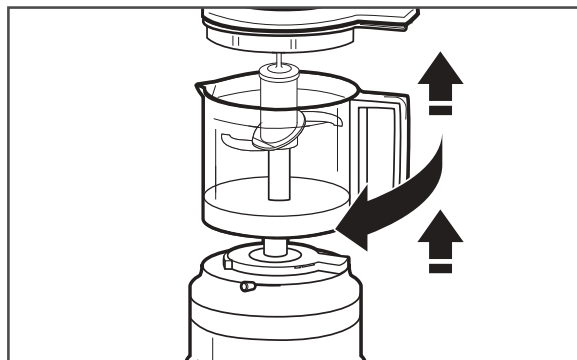

- 1** Unplug the Mini Food Processor. Remove the work bowl, lid, and blade.

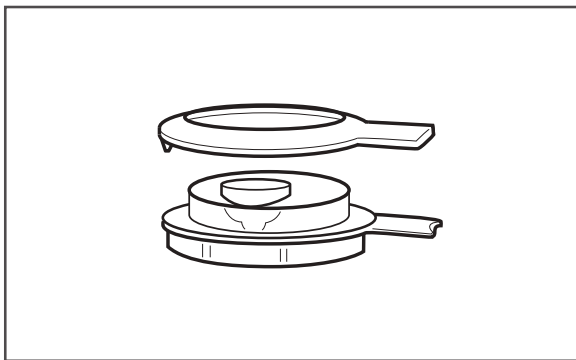

**OPTIONAL:** The lid ring can be removed for more detailed cleaning if necessary.

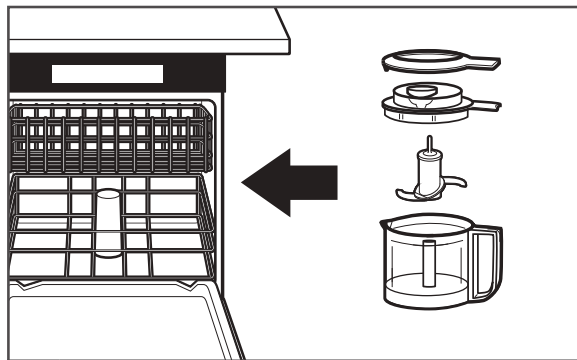

- 2** The work bowl, lid, lid ring, and blade can be washed in the top dishwasher rack or, wash all parts in hot, soapy water. Rinse and dry.

## CARE AND CLEANING

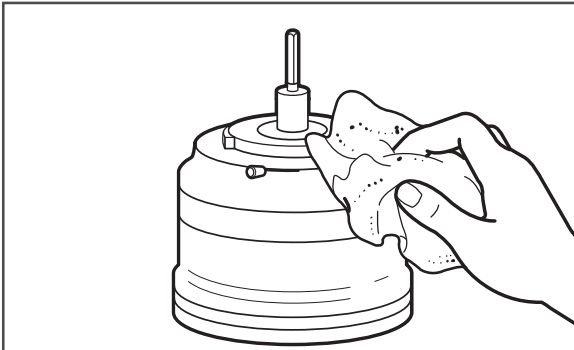

**3**

Wipe the base clean with a damp cloth. Do not use abrasive cleaners. Do not immerse the base in water.

**HELPFUL TIP:** Wrap the cord counterclockwise around the base for easy storage.

**NOTE:** For convenient storage, always reassemble the Mini Food Processor after cleaning.

## TROUBLESHOOTING

**If your Mini Food Processor should malfunction or fail to operate, check the following:**

1. Is the Mini Food Processor plugged in?
2. Make sure that the bowl and lid are properly aligned and locked in place.
3. Press the PULSE/ON button with a rapid up and down motion. Do not hold down continuously.
4. Unplug the Mini Food Processor, then plug it back into the outlet.
5. Is the fuse in the circuit to the Mini Food Processor in working order? If you have a circuit breaker box, be sure the circuit is closed.

If the problem is not due to one of the above items, see the "Warranty and service" section.

Do not return the Mini Food Processor to the retailer. Retailers do not provide service.

# WARRANTY AND SERVICE

## KITCHENAID MINI FOOD PROCESSOR WARRANTY

Length of Warranty:	KitchenAid Will Pay For:	KitchenAid Will Not Pay For:
<b>Europe, Middle East and Africa: 5KFC3516</b> Two years full warranty from date of purchase.	The replacement parts and repair labour costs to correct defects in materials or workmanship. Service must be provided by an Authorised KitchenAid Service Centre.	<b>A. Repairs when Mini Food Processor is used for operations other than normal household food preparation.</b> <b>B. Damage resulting from accident, alterations, misuse, abuse, or installation/operation not in accordance with local electrical codes.</b>

**KITCHENAID DOES NOT ASSUME ANY RESPONSIBILITY FOR INDIRECT DAMAGES.**

## CUSTOMER SERVICE

### In U.K. and Ireland:

For any questions, or to find the nearest Authorised KitchenAid Service Centre, please find our contact details below.

**NOTE:** All service should be handled locally by an Authorised KitchenAid Service Centre.

Contact number for U.K. and Northern Ireland:

Tollfree number 0800 988 1266 (calls from mobile phones are charged standard network rate) or call 0194 260 5504

Contact number for Ireland:

Tollfree number +44 (0) 20 8616 5148

E-mail contact for U.K. and Ireland:

Go to [www.kitchenaid.co.uk](http://www.kitchenaid.co.uk) and click on the link "Contact Us" at the bottom of the page.

Address for U.K. and Ireland:

KitchenAid Europa, Inc.  
PO BOX 19  
B-2018 ANTWERP 11  
BELGIUM

General hotline number:



00800 3810 4026

### In other countries:

For all product related questions and after-sales matters, please contact your dealer to obtain the name of the nearest Authorised KitchenAid Service/Customer Centre.

**For more information, visit our website at:**

**[www.KitchenAid.co.uk](http://www.KitchenAid.co.uk)**  
**[www.KitchenAid.eu](http://www.KitchenAid.eu)**

©2017 All rights reserved.

Specifications subject to change without notice.

# KitchenAid

©2017 All rights reserved.  
Specifications subject to change without notice.

W10860735B

03/17